

## Vortex Flow Sensors VA 05/2004

Probes · Probe Extensions · Probe Guides



Flow · Flow rate  
also combined with  
temperature · Pressure

Specifications  
Designs  
Information for the user

Experience with  
vortex flow sensors



Vortex street

derived from the Karman phenomenon of vortex shedding, is based on vortices being shed when a flowing medium reaches an obstruction or strut, whereby the vortex shedding frequency is a dimension for the flow velocity.

The flow vortices are ultrasonically scanned. In this way, compared to other scanning methods, the lower flow velocities can be measured and a greater turndown ratio can be obtained. The vortices modulate the ultrasonic beam between an ultrasonic transmitter and receiver. The vortex frequency results from the demodulation.

A great advantage of the vortex principle of measurement is well-founded - when measuring within the respective specifications - in the independence of density, pressure and temperature from the working medium.

Vortex measuring probes have no moving parts. Even in rough conditions they prove to have outstanding fatigue strength, excellent repeatability, long-term stability are overload-proof and interchangeable. Measuring is practically inertia-free. The length of cable between sensor and electronic evaluation unit can measure up to several hundred meters.

TÜV qualification tested

for continuous measurement of exhaust flow rate in the case of officially approved outgoing air plants, garbage incinerating plants and industrial furnaces according to TA-Luft, 13th and 17th BImSchV.

**Types of sensor with vortex flow sensors**

- v-sensors for measuring the flow velocity v: VA
- vt-sensors for measuring the flow velocity v and also the temperature t: VAT

- v-sensors for sensing the  $\pm$ direction of flow: VAR
- v-sensors VA and VAR in protective system  $\odot$  EEx ia IIC T6 only permissible in Germany for zone 1.
- v-sensors VA as in drawing 6 in protective system  $\odot$  EEx ia IIC T6 for zone 0 in Germany.



U155\_VA\_D\_e\_040525

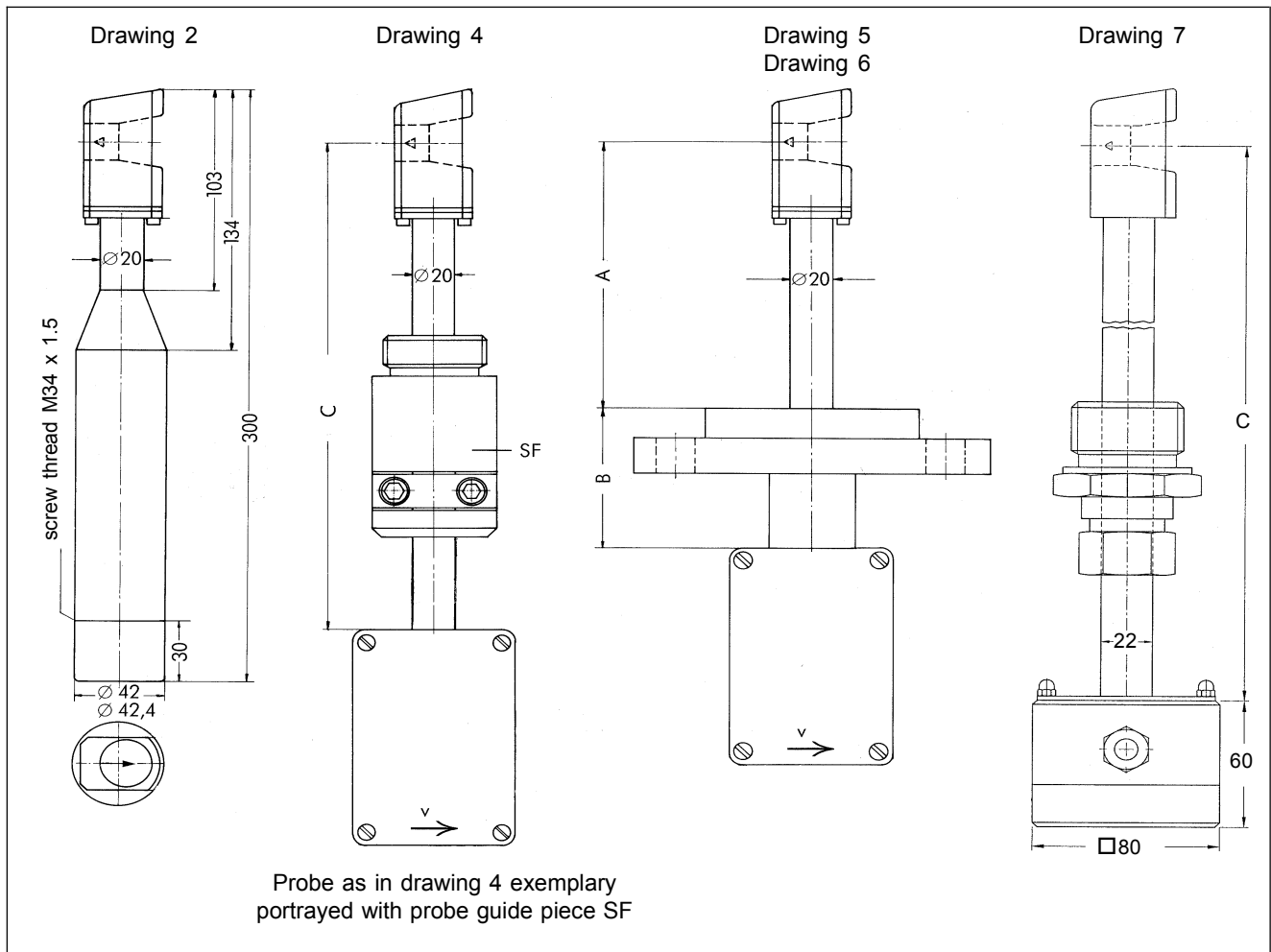

### Designs

- extendable probes VA40/42 as in drawing 2 are determined for insertion into mediums with greater insertion depths, for instance greater than 1 m. When screwed together with extension tubes they can be moved to determine the best measuring position.
- probes VA40/20 of an exact length as in drawing 4 are for insertion in mediums with insertion depths of up to approx. 1.5 m. These can also be moved to determine the best measuring position.
- probes VA40/22 of an exact length as in drawing 7 are for insertion in mediums with insertion depths of up to 1 m. These can also be moved.
- probes VA40/20 of an exact length as in drawing 5 are for insertion in mediums with lesser to medium insertion depths. The measuring position is determined by the inside diameter of the pipe and the length of the single ended flanged nipple.

- probes VA40/20 of an exact length as in drawing 6 are for insertion in mediums with lesser to medium insertion depths when an Ex-requirement for zone 0, that is, when continued explosion hazard exists. The measuring position is determined by the inside diameter of the pipe and the length of the single ended flanged nipple.
- vortex flow sensors VAR40 sensing +/-direction of flow are, for instance, suitable for measurement of flow in traffic and waste dump tunnels.

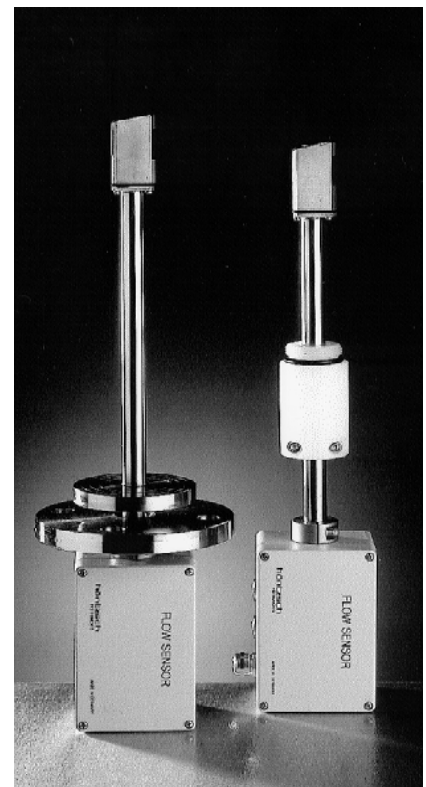
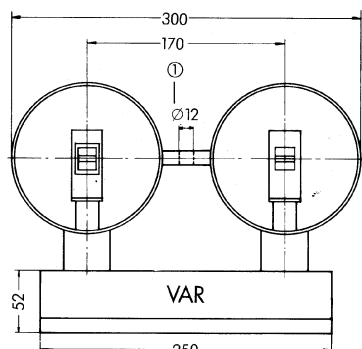

## Model designations of the vortex probes VA40

### Types of sensor

- VA vortex flow sensor, v-sensor  
VA with 3 conductors
- VAT vortex flow sensor with integrated temperature probe Pt100, vt-sensor:  
v-sensor VA with 3 conductors;  
t-sensor Pt100, DIN IEC 751, tolerance 1/3 class B, 4-wire configured

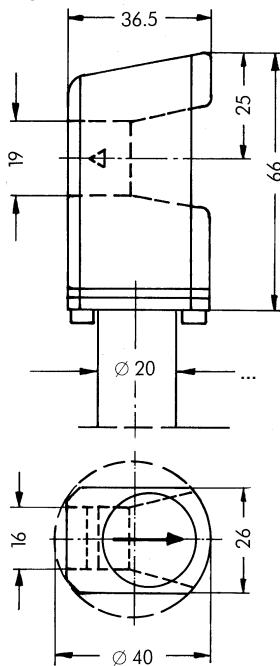

### Width across corners

VA40 probes have a rectangular shape with 40 mm width across corners favourable for flow. Therefore they have to have insertion openings with a hole diameter larger than 40 mm for insertion in pipe lines or ducts.

### Probe tube diameter from sensor

The connecting tube for all VA40 vortex flow sensors has a diameter of 20 mm, beginning at the sensor housing. VA40/42 probes expand approx. 40 mm after the sensor housing and then have a diameter of 42 mm or 42.4 mm respectively. The advantage of the VA40/42 is that the sensor housing can be fed through the boring of a probe guide piece or globe cock with a diameter of 42 mm or rather 42.4 mm. VA40/42 probes have a connection thread onto which the probe tube can be screwed for extension purposes.

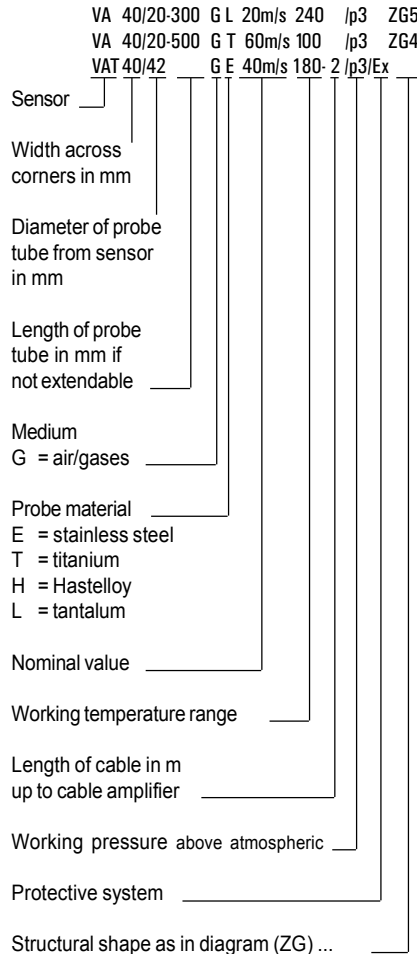

The choice of materials should be made with a view to the required corrosion resistance. Hastelloy B2 upon request. Instead of the standard seal material VITON®, KALREZ® or, for low temperatures, SILICONE, are also available on request.

### Medium

G air/gases

Vortex flow sensors VA40 are primarily intended for measurements in single-phase flow gas: air, gas mixtures with air, oxygen or nitrogen as a predominant constituent, methane, natural gas, torch gas, ammonia, argon, carbon monoxide, steam ...

Permissible are non-dominant admixtures of carbon dioxide, chlorine, fluorine, helium, hydrogen ...  
Not suitable however are gas mixtures consisting predominantly of carbon dioxide, chlorine, fluorine, helium, hydrogen ...

Impurities in gases in the form of solids are of no impairment as long as abrasion does not result. In comparison to Höntzsch vane wheel flow sensors, vortex flow sensors can be used for measuring in gases with a considerably intensive solids content, without impairing the fatigue strength. The medium may even contain fibres.

### Sensor materials

- E** stainless steel
  - sensor housing titanium 1.4581
  - ceramics
  - connection tubes 1.4571
  - seals VITON®
- T** titanium
  - sensor housing titanium 3.7161
  - ceramics
  - connection tubes titanium
  - seals VITON®
- H** Hastelloy
  - sensor housing Hastelloy C4 2.4610, optional Hastelloy C22, ceramics
  - connection tubes Hastelloy
  - seals VITON®
- L** tantalum
  - sensor housing tantalum
  - ceramics
  - connection tubes tantalum
  - seals VITON®

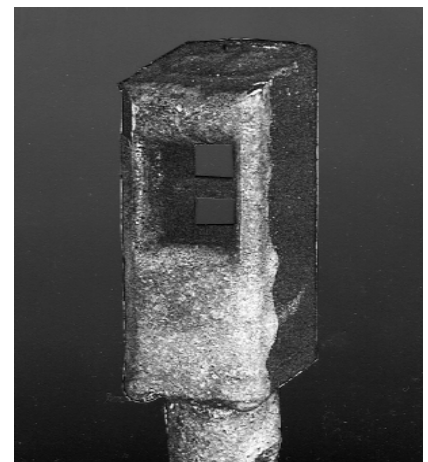

The pictured sensor with salt deposits was installed for several weeks in a bore hole for ventilation. The slight deposits on the strut can be easily seen. In soiled condition drifts of max. ±0.3 m/s result for velocities of up to approx. 12 m/s.

Likewise moisture in gases is of no disadvantage, as long as condensation does not set in. Should condensation arise it can influence measurement. The limits between 100 % saturated flow of gas, occasional condensation on the sensor, severe or slight condensation, are flowing. However, the possibility of measurement being influenced by condensation can be kept to a minimum when

- the sensor is positioned horizontally when occasional or slight condensation arises. This makes drainage easier at the strut and ultrasonic transmitter and receiver.
- the vortex signal processing module **VSM wet gases** is used when severe but not continually severe condensation arises. In the case of continual and severe condensation faulty measurements may still arise for the duration, even when using the VSM, especially when the velocity lies under approx. 4 m/s.

### Measuring range

The smallest measurable value during velocity measuring  $v$  is dependent on diameter/width across corners  $d$  of the strut as well as the kinematic viscosity  $\nu$  of the gas and consequently on its density  $\rho$  or temperature.

It is well-known from scientific research that shedding of vortices arises in a vortex street with Reynolds number  $Re > 70 \dots 100$ . From the relation

$$Re = \frac{v \cdot d}{\nu}$$

the smallest measurable value

$$v (+20 \text{ }^\circ\text{C}) = 0.38 \text{ m/s}$$

$$v (+180 \text{ }^\circ\text{C}) = 0.81 \text{ m/s}$$

for the Höntzsch strut with diameter/width across corners  $d = 4 \text{ mm}$  e.g. with air under normal atmospheric conditions can be calculated with

$$v (+20 \text{ }^\circ\text{C}) = 15.13 \cdot 10^{-6} \text{ m}^2/\text{s}$$

$$v (+180 \text{ }^\circ\text{C}) = 32.43 \cdot 10^{-6} \text{ m}^2/\text{s}$$

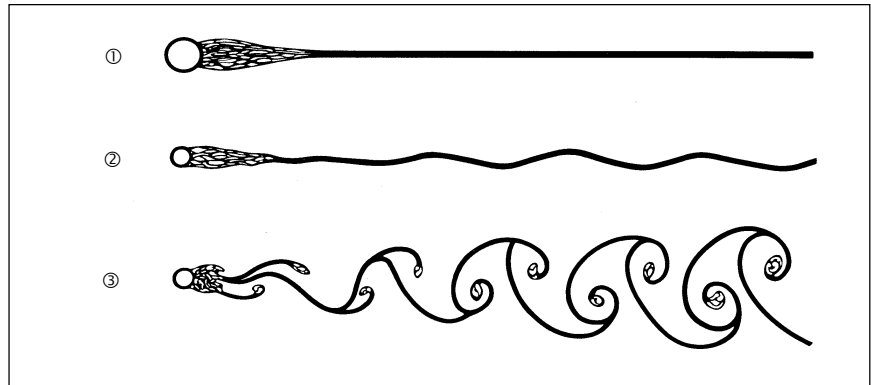

Vortex pattern downstream of a cylinder in a range of very low Reynolds' numbers according to Homann.

①  $Re \approx 32$     ②  $Re \approx 50$     ③  $Re \approx 70$

The kinematic viscosity  $\nu$  is defined as the ratio between dynamic viscosity  $\eta$  and density  $\rho$

$$\nu = \eta/\rho$$

The greater the density of medium, for instance as a result of higher pressure, the lesser the kinematic viscosity, and the lesser the kinematic viscosity, this results from the aforementioned equation for the Reynolds' number, the lesser the smallest measurable value.

The frequency  $f$  of the shedding of vortices is determined by

$$f = \frac{S \cdot v}{d}$$

when  $S =$  Strouhals' number. It can be seen from the relation of Strouhals' number  $Re$ , that the Strouhals' number is constant for large Reynolds' number range, the shedding frequency is consequently independent of temperature, density, pressure and viscosity.

Typical shedding frequency for the VA40 sensor with triangular strut:

$$1 \text{ m/s} = 63 \text{ Hz}$$

$$20 \text{ m/s} = 1450 \text{ Hz}$$

The nominal value can be adapted to the measuring function and designated to 20/25/30/35/40/60/80 m/s. Terminal value 25 m/s is necessary for application in installations according to TA-Luft, 13th and 17th BImSchV. Terminal value 80 m/s requires additionally the vortex signal processing module VSM.

The velocity overload capacity of the vortex flow sensor VA40 is one of its outstanding features. It withstands up to 80 m/s. Because of the mechanically stable design of the probe even greater overload capacity can be expected. If the flow velocity is greater than the probe individual nominal value, then the measured value is, as a rule, lower than actual velocity value, seldom however lower than the specified nominal value.

Vortex flow sensors are determined, to a large extent, for measurement of uniform flow velocities. Flow conditions as in the case of pulsating flow or oscillating flow can influence measuring dependent from frequency ( $>5 \text{ Hz}$ ) and amplitude ( $>0.3 \text{ m/s}$ ). High endurance of the vortex flow sensors follows independent of flow conditions within the measurement range and independent of velocity overloading.

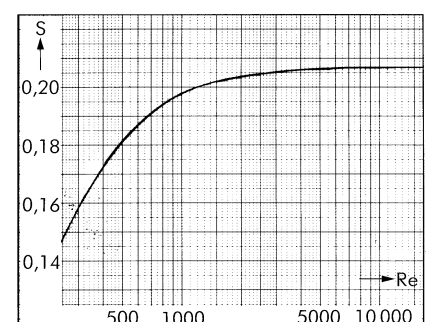

## Working temperature range

100	-20 °C... +100 °C	<b>C</b> VITON
	-25 °C... +105 °C	<b>S</b> VITON
	0 °C... +100 °C	<b>C</b> KALREZ
	0 °C... +105 °C	<b>S</b> KALREZ
180	-20 °C... +180 °C	<b>C</b> VITON
	-25 °C... +205 °C	<b>S</b> VITON
	0 °C... +180 °C	<b>C</b> KALREZ
	0 °C... +205 °C	<b>S</b> KALREZ
240	-20 °C... +240 °C	<b>C</b> VITON
	-25 °C... +250 °C	<b>S</b> VITON

**C** = continuous operation  
**S** = short-time operation

The respective sensor working temperature range is especially influenced by the materials of the ultrasonic transmitter and receiver, the cable, as well as the seals.

Measurements at temperatures for which short-time operation is specified should only last for a few minutes. If this advice is adhered to, then the measuring probe cannot be damaged. In the case of vt-sensors the working temperature range corresponds to the temperature measurement range. Continuous working temperature range at temperatures higher than +100 °C or rather lower than -25 °C is moreover achieved by the active electronic components in a so-called cable amplifier being positioned at a distance from areas with high/low temperatures. The cable amplifier can be found, in the case of VA40/42 probes, in a bush on the sensor connection cable or, with VA40/20 designs, in the connection housing. Permissible temperatures at the cable amplifier:

-25... +100 °C. In order to keep to these regulations, in individual cases ambient temperature, the heat flow above the sensor connection cable or probe tube up to connection housing as well as eventual thermal radiation must be paid attention to. A cable length of 0.4 m is sufficient between the place at which a sensor connection cable comes out of a zone of for example +240 °C up to the bush with cable amplifier, when the cable amplifier is in surroundings with temperatures of no more than +40 °C.

## Cable amplifier in a bush

Cable length up to cable amplifier  
 Standard length 2 m. For example, the sensor identification 180-2 or

180-10 means that the sensor is resistant up to +180 °C and the length of cable between sensor and bush with cable amplifier is either 2 m or 10 m.

Type of cable up to cable amplifier  
 PTFE-coated.

Cable after cable amplifier  
 Standard length 2 m. SILICONE-coated and temperature resistant up to +100 °C. Sensors for +100 °C also have as standard a 2 m long SILICONE-coated connection cable for max. +100 °C.

When ordering please name the accompanying evaluation unit so that the appropriate connector plug / connection identification can be supplied.

## Warning:

Do not sever or shorten the cable between probe and cable amplifier!

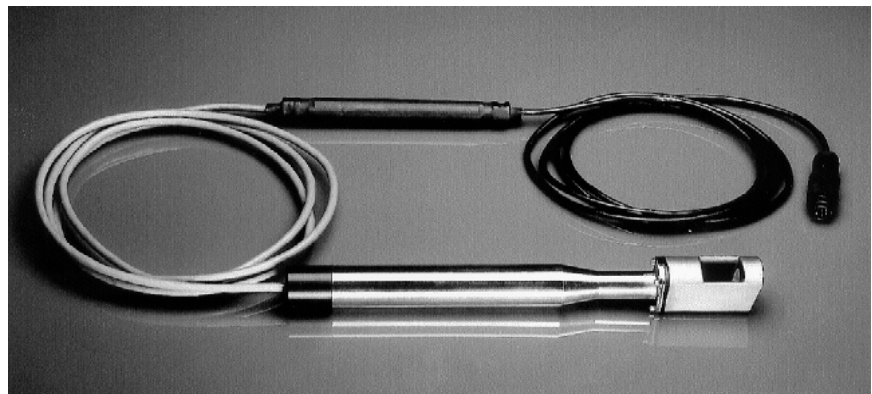
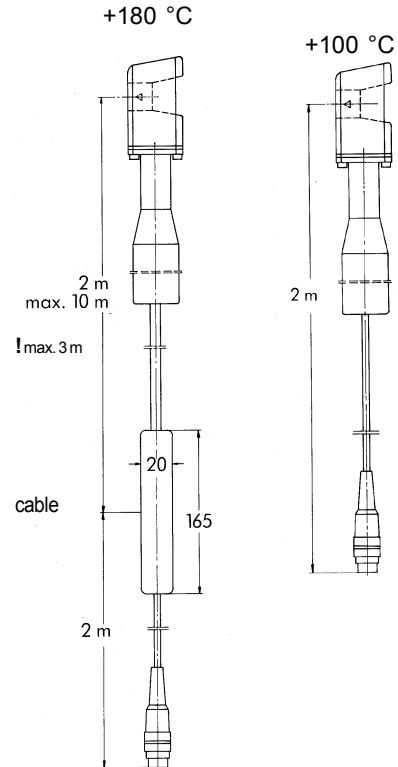

Cable amplifiers in a bush are moisture-proof but not impervious to aggressive gases.

## Maximum working pressure

p3 sensor is tight and pressure resistant up to 3 bar/300 kPa

## Protective system

### Explosion protection

v-sensors are also available in compliance with EN 50 014 and EN 50 020 or 94/9/EG **ATEX 100a** in protective system **Ex ia IIC T6**, electric circuit intrinsically safe.

v-sensors VA40/20 ZG6 are in protective system **Ex ia IIC T6** and determined for zone 0 also in Germany.

## Protection against medium

Neither liquids nor corrosive gases must be allowed to penetrate the sensor from the cable connection side. In this respect please enquire about protected sensors, e.g. for use in aggressive gases, before ordering.

## Seal materials

Standard material is VITON®. KALREZ® or SILICONE as an option to VITON®.

Working temperature range of the seal materials:

VITON	-20 °C... +240 °C	<b>C</b>
	-25 °C... +250 °C	<b>S</b>
KALREZ	0 °C... +300 °C	<b>C</b>
PTFE/TEFLON	-40 °C... +260 °C	<b>C</b>
	-40 °C... +300 °C	<b>S</b>

® DuPont trademark

## Probe extensions SR

are used for deeper insertion of probes in mediums, when the standard probe length is not sufficient for the required insertion depth.

Extendable probes VA40/42 or VA40/42.4 have, for this purpose, a connection thread onto which extension tubes can be fitted which are also suited for feed-through of sensor connection cable, if necessary bush with cable amplifier and connector plug. In addition they are protected against mediums - water or corrosive gases - which should not be allowed to penetrate the sensor from the cable connection side. Probe tubes are suitable for use with probe guide pieces, even in corrosive mediums or at high temperatures and offer a mechanically steady probe support.

Probe tubes made of titanium can be manufactured only together with a complete order with the same diameter. The diameter of these tubes may differ slightly from the respective nominal diameter. Probe guide pieces must be manufactured to match these probe tubes.

The mechanical burden of the tubes on the connection threads (burden due to weight of probe and extension tube as well as force of the flowing medium) limits the number of extension tubes which can be screwed together. Besides this, the sensor must not be allowed to undergo any vibration. For the most cases we recommend that not more than 4 extension tubes of 350 mm or 500 mm in length or rather 2 extension tubes of 1000 mm in length should be screwed together without additional support.

### Seal materials

As a rule VITON O-rings are suitable on the screw fittings of extension tubes.

KALREZ O-rings can only be recommended if the corrosion resistance of VITON should not be adequate. KALREZ O-rings are temperature resistant for certain mediums, according to DuPont, in a range from 0 °C ... +300 °C. KALREZ O-rings available on request.

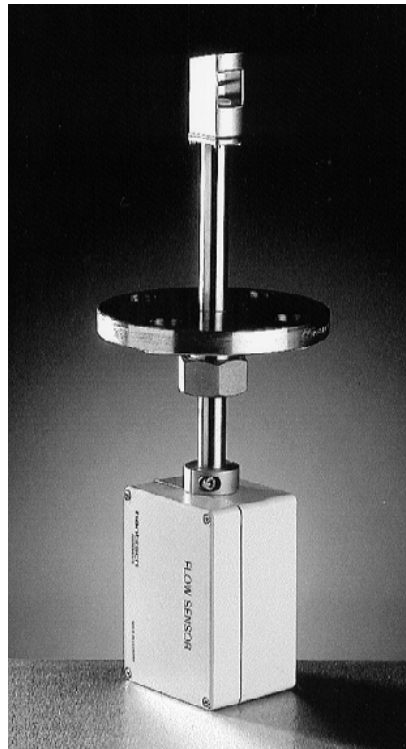

SFB with flange

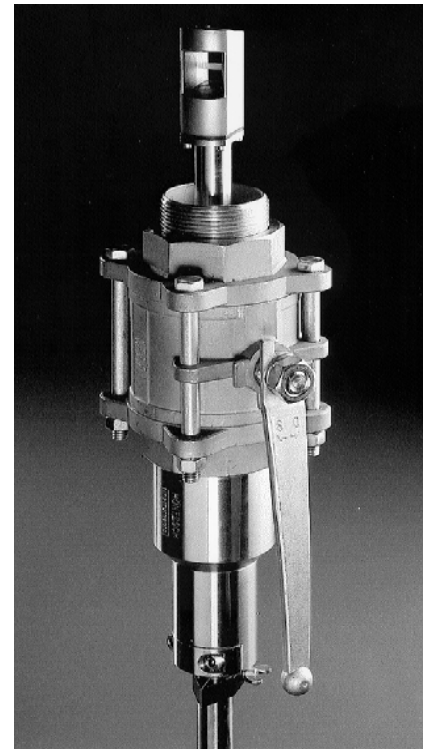

SFZ with globe cock

## Probe guide pieces SF

are used for inserting and retracting probes in and out of pipelines and ducts. The fixing device of the probe tube is to be chosen taking the temperature and pressure operating conditions into consideration.

SFB SF with clamping bush for unlimited repeated positioning of a probe at low sub-atmospheric and above atmospheric pressures

SFZ SF with collet chuck for unlimited repeated positioning of a probe at sub-atmospheric pressures/pressures above atmospheric of up to 10 bar

SFK SF with clamp strap for unlimited repeated positioning of a probe at sub-atmospheric pressures/pressures above atmospheric of up to 10 bar

**Coefficient/Profile factor CF = PF**

In larger free jet as well as in larger ducts and measuring tubes the local velocity  $v_p$  will be displayed with  $PF = 1.000$ . PF is also used to calculate the local velocity  $v_p$  to the average velocity  $v_m$  in a measurement cross-section:

$$v_m = v_p \cdot PF$$

When measuring with vortex flow sensors VA40 in circular measurement cross-sections with interior diameter  $D_i$

- centric positioning of the sensor
- irrotational flow
- developed flow profile (measurement cross-section so chosen, that 20  $D_i$  straight, unhindered input section amounts to 10  $D_i$  straight, unhindered output section)

following coefficients are to be taken as a basis:

$D_i$	PF	$D_i$	PF
80	0.719	160	0.808
90	0.729	170	0.819
100	0.738	180	0.830
110	0.750	190	0.839
120	0.761	200	0.842
130	0.773	300	0.845
140	0.784	400	0.850
150	0.796	...	0.850

If these conditions for application of the coefficients are not prevailing then a pre-examination of flow should be carried out in the greater measurement cross section with  $PF = 1.000$ . As a result of this examination an optimal measurement point is to be determined and the corresponding coefficient is to be set.

For further information please consult VDI/VDE 2640, "Measurement of velocity area methods in flow cross-sections".

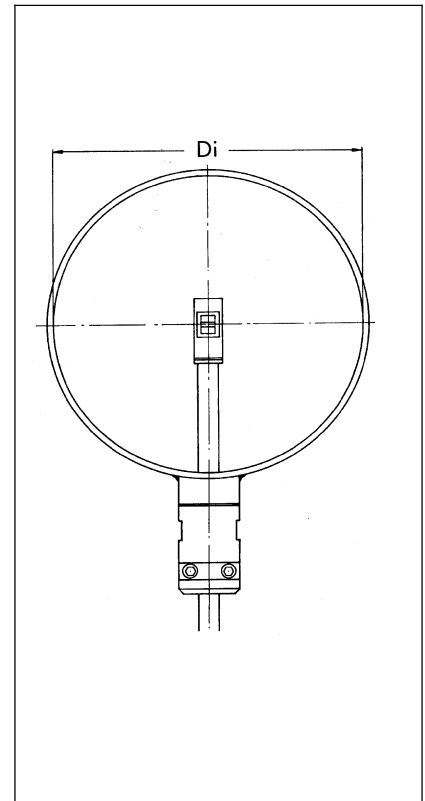

Design,  
Manufacture, Sales

Flow · Flow rate also  
combined with  
temperature · Pressure

Electronic measurement  
of physical values

Control, regulation and  
recording equipment

**Höntzsch GmbH**  
P.O. Box 1324 D-71303 Waiblingen  
Robert-Bosch-Str. 8  
D-71334 Waiblingen (Hegnach)  
Telephone 07151/1716-0  
Facsimile 07151/58402  
E-Mail [info@hoentzsch.com](mailto:info@hoentzsch.com)  
Internet [www.hoentzsch.com](http://www.hoentzsch.com)

Subject to alteration